

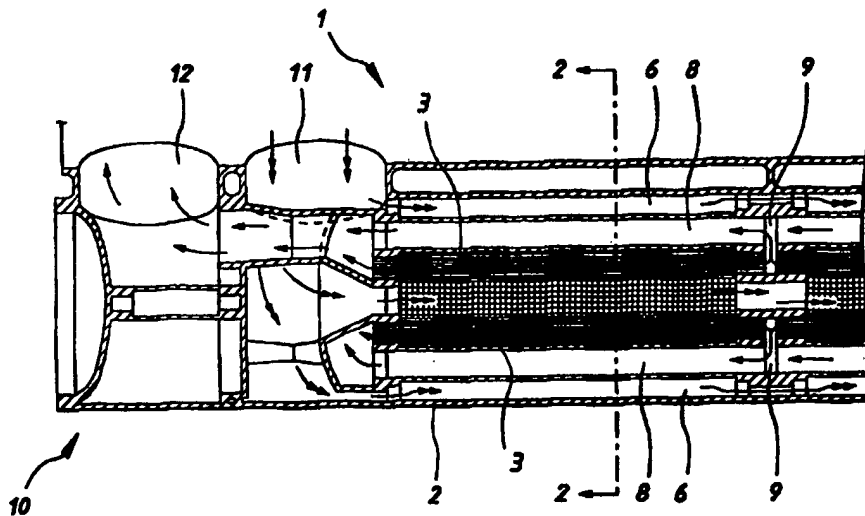

INTERNATIONAL APPLICATION PUBLISHED UNDER THE PATENT COOPERATION TREATY (PCT)

<p>(51) International Patent Classification ⁶ : B01D 63/02 // 63/04, 61/18</p>	<p>A1</p>	<p>(11) International Publication Number: WO 98/25694 (43) International Publication Date: 18 June 1998 (18.06.98)</p>
<p>(21) International Application Number: PCT/AU97/00835 (22) International Filing Date: 9 December 1997 (09.12.97) (30) Priority Data: PO 4125 10 December 1996 (10.12.96) AU (71) Applicant (for all designated States except US): MEMTEC AMERICA CORPORATION [US/US]; Suite 700, 9690 Deereco Road, Timonium, MD 21093 (US). (72) Inventor; and (75) Inventor/Applicant (for US only): BILTOFT, Bruce, Gregory [AU/AU]; 51 Park Avenue, Chatswood, NSW 2067 (AU). (74) Agent: SHELSTON WATERS; 60 Margaret Street, Sydney, NSW 2000 (AU).</p>		<p>(81) Designated States: AL, AM, AT, AU, AZ, BA, BB, BG, BR, BY, CA, CH, CN, CU, CZ, DE, DK, EE, ES, FI, GB, GE, GH, GM, HU, ID, IL, IS, JP, KE, KG, KP, KR, KZ, LC, LK, LR, LS, LT, LU, LV, MD, MG, MK, MN, MW, MX, NO, NZ, PL, PT, RO, RU, SD, SE, SG, SI, SK, SL, TJ, TM, TR, TT, UA, UG, US, UZ, VN, YU, ZW, ARIPO patent (GH, GM, KE, LS, MW, SD, SZ, UG, ZW), Eurasian patent (AM, AZ, BY, KG, KZ, MD, RU, TJ, TM), European patent (AT, BE, CH, DE, DK, ES, FI, FR, GB, GR, IE, IT, LU, MC, NL, PT, SE), OAPI patent (BF, BJ, CF, CG, CI, CM, GA, GN, ML, MR, NE, SN, TD, TG).</p> <p>Published With international search report.</p>

(54) Title: IMPROVED MICROPOROUS MEMBRANE FILTRATION ASSEMBLY



(57) Abstract

A filter assembly (1) comprising an elongate housing (2) having therein a plurality of discrete filter bundle lengths (3) disposed end to end in a series configuration. Each filter bundle length (3) comprises a multitude of microporous polymeric hollow fibres of the kind wherein feed to be filtered is fed to the outside of the bundle of fibres and permeate is extracted from one or both permeate discharge ends (4) of the fibre lumens. The system also includes one or more longitudinally extending feed passages (6 and 7) and one or more longitudinally extending permeate return passages, each of the permeate return passages being in fluid flow communication with each of the permeate discharge ends (4) of the fibre lumens, desirably via connecting passages (9).

FOR THE PURPOSES OF INFORMATION ONLY

Codes used to identify States party to the PCT on the front pages of pamphlets publishing international applications under the PCT.

AL	Albania	ES	Spain	LS	Lesotho	SI	Slovenia
AM	Armenia	FI	Finland	LT	Lithuania	SK	Slovakia
AT	Austria	FR	France	LU	Luxembourg	SN	Senegal
AU	Australia	GA	Gabon	LV	Latvia	SZ	Swaziland
AZ	Azerbaijan	GB	United Kingdom	MC	Monaco	TD	Chad
BA	Bosnia and Herzegovina	GE	Georgia	MD	Republic of Moldova	TG	Togo
BB	Barbados	GH	Ghana	MG	Madagascar	TJ	Tajikistan
BE	Belgium	GN	Guinea	MK	The former Yugoslav Republic of Macedonia	TM	Turkmenistan
BF	Burkina Faso	GR	Greece			TR	Turkey
BG	Bulgaria	HU	Hungary	ML	Mali	TT	Trinidad and Tobago
BJ	Benin	IE	Ireland	MN	Mongolia	UA	Ukraine
BR	Brazil	IL	Israel	MR	Mauritania	UG	Uganda
BY	Belarus	IS	Iceland	MW	Malawi	US	United States of America
CA	Canada	IT	Italy	MX	Mexico	UZ	Uzbekistan
CF	Central African Republic	JP	Japan	NE	Niger	VN	Viet Nam
CG	Congo	KE	Kenya	NI	Netherlands	YU	Yugoslavia
CH	Switzerland	KG	Kyrgyzstan	NO	Norway	ZW	Zimbabwe
CI	Côte d'Ivoire	KP	Democratic People's Republic of Korea	NZ	New Zealand		
CM	Cameroon			PL	Poland		
CN	China	KR	Republic of Korea	PT	Portugal		
CU	Cuba	KZ	Kazakstan	RO	Romania		
CZ	Czech Republic	LC	Saint Lucia	RU	Russian Federation		
DE	Germany	LI	Liechtenstein	SD	Sudan		
DK	Denmark	LK	Sri Lanka	SE	Sweden		
EE	Estonia	LR	Liberia	SG	Singapore		

TITLE: IMPROVED MICROPOROUS MEMBRANE FILTRATION**ASSEMBLY**FIELD OF THE INVENTION

The present invention relates to filtration processes and apparatus of the kind using
5 microporous membranes, wherein feed containing contaminant matter is applied under
pressure to a feed receiving surface of the membrane for passage therethrough and
wherein filtrate is withdrawn from the permeate side of the membranes.

More particularly, the invention relates to systems using microporous filters
comprising elongate bundles of microporous polymeric fibres, wherein feed to be
10 filtered is fed to the outside of the bundles of fibres and permeate is extracted from the
ends of the fibre lumens. The systems also preferably incorporate a backwashing facility
for periodic cleansing of the feed surfaces of the fibres.

BACKGROUND OF THE INVENTION

Typical prior art filter systems of the type described above generally include
15 elongate tubular cartridges enclosing a bundle of the microporous hollow fibres.
Manifold or header arrangements are then used to connect the cartridges, usually at one
or both ends, these manifolds acting to separate and divert the respective flows of
contaminated feed and permeate through the system. In this regard, cross-flow systems
typically have two feed manifolds (inlet and re-circulation outlet) and one or two
20 permeate manifolds. In cross-flow filtration systems of the prior art the stream to be
filtered, flows tangential to or across the surface of the membrane. This generates a
sweeping action at the membrane surface, keeping the surface cleaner. Conversely,
systems configured for dead end operations have only one feed inlet manifold and one

permeate outlet manifold. Further, these prior art manifolds or header arrangements are often configured to facilitate the construction of modular two or three dimensional cartridge arrays.

It should be noted that these systems operate under significant internal pressures.

5 Accordingly, the cartridge casings and header manifold structures need to be made from high strength, and thereby correspondingly high cost, materials such as stainless steel and higher grade reinforced plastic materials specifically designed to withstand these pressures.

Most of the prior art designs available to date have proved satisfactory for small to
10 medium scale applications. However, as there is now an increasing demand for larger scale systems, the current structures are proving to be prohibitively expensive due, for example, to the additional amount of connecting pipe work required and the costs of the componentary associated with each individual cartridge.

When attempting to design larger systems, it is not simply a matter of scaling up
15 all the individual components. This is due, in part, because it is preferred that the individual constituents of the system remain sized so as to be readily man handleable for the purpose of assembly and maintenance. Further, as the structures themselves and associated flow paths get larger, the problems with pressure drops through the system become more significant.

20 It is an object of the present invention to provide a modified filtration assembly of the kind herein before described which overcomes or substantially ameliorates at least some of the disadvantages of the prior art or at least offers a useful alternative thereto.

DISCLOSURE OF THE INVENTION

According to a first aspect of the invention there is provided a filter assembly comprising:

an elongate housing having a plurality of discrete filter bundle lengths disposed
5 end to end in a series configuration, each filter bundle comprising a multitude of
microporous polymeric hollow fibres, wherein feed to be filtered is fed to the outside of
the bundle of fibres and permeate is extracted from one or both discharge ends of the
fibre lumens;

one or more feed passages extending longitudinally along said housing to direct
10 feed to said filter bundle lengths;

one or more longitudinally extending permeate return passages extending generally
parallel to said filter bundle length, said permeate return passages being sealed from
contact with said feed and adapted to be in fluid flow communication with each of said
permeate discharge ends of said fibre lumens in said filter bundle lengths; and

15 one or more manifold arrangements, each having a feed inlet port connecting with
said one or more longitudinally extending feed passages and a separate permeate outlet
port connected with said one or more permeate return passages.

In a preferred form, the manifold arrangements are disposed at one or both
longitudinal ends of said housing and are configured to connect a plurality of the filter
20 assemblies into banks.

Advantageously, the housing can include two, three or four filter bundle lengths
disposed end to end in a series configuration. More preferably, each longitudinal length
of the housing also has therein two or more co-extending filter bundle lengths that are

each similarly connected in series to adjacent filter bundle lengths. In this manner, large systems can be constructed using filter bundle lengths or sub-modules that are of a size that are readily manhandable.

In one form co-extensive filter bundle lengths are interconnected as a sub-
5 assembly of multiple filter bundle lengths. Preferably, each bundle length is separately potted in the conventional manner described in more detail hereafter.

In yet other forms, the invention provides an elongate housing containing at any one point four co-extensive filter bundles with three or four such filter bundle lengths connected in series. In a preferred form a peripheral feed passage is provided that is
10 generally parallel to the external walls of the housing that is desirably no more than about 15mm in radial depth at any point, together with a central feed passage that passes through the centre of the four co-extensive filter bundle lengths. In one form, the peripheral feed passage and/or central feed passage may be configured, by the use of
15 packing material for example, to assist in directing the flow of feed both around and into the filter bundles.

It is further preferred that four separate permeate return tubes are provided that are equally spaced within the housing intermediate the central and peripheral feed passages.

Manifold arrangements in the form of headers are preferably provided at both longitudinal ends of the housing to facilitate cross-flow filtration, wherein a portion of
20 the feed can be discharged from the other end for recirculation. The feed outlet port can also be used as a flushing fluid inlet port for operation during the backwashing process, wherein fluid under pressure is applied to the inner surface of the fibre lumens via the filtrate or permeate outlet ports and a backwashing fluid is subsequently applied to the

external surfaces of the fibres to flush out any accumulated contaminants that may have been dislodged from the fibres.

It is also preferred, particularly in systems utilising large diameter filter bundles, to provide feed passages through the centre of each individual filter bundle.

5 Finally, other preferred forms of the invention could also include means to isolate individual filter assemblies or banks of assemblies in the event of failure of a filter bundle. This is achieved in one embodiment by means of individual valves associated with each filter bundle length, filter assembly housing, or manifold arrangement, as required.

10

BRIEF DESCRIPTION OF THE DRAWINGS

A preferred embodiment of the invention will now be described, by way of example only, with reference to the accompanying drawings in which:

Figure 1 is a longitudinally sectioned part view of a first embodiment filtration system according to the invention having four co-extensive filter bundles and filtrate
15 return passages;

Figure 2 is a transverse section taken on line 2-2 of Figure 1;

Figure 3 is a more detailed longitudinally sectioned part view of a very similar system to that shown in Figure 1;

Figure 4 is an enlarged detailed transverse section of the system shown in Figure 3;

20 Figure 5 is a cut away perspective part view of a second embodiment filtration module having three filter bundles and three filtrate return passages;

Figure 6 is a schematic side view of a three dimensional array constructed using the modules illustrated in the previous Figures;

Figure 7 is an end view of the filter assembly shown in Figure 6;

Figure 8 is a first graph showing the results of a first performance comparison test of trans membrane pressure drop for the present invention against the applicants standard M10C filtration system; and

5 Figure 9 is a second graph showing the results of a second performance comparison test of trans membrane pressure drop for the present invention against the applicants standard M10C filtration system.

PREFERRED EMBODIMENT OF THE INVENTION

Referring to the drawings, the filter assembly 1 includes an elongate housing 2
10 having therein a plurality of filter bundles 3 disposed end to end in a series configuration. In the embodiment illustrated in figures 1 and 2, there are 4 sets of co-extending filter bundles each connected in series to an adjacent four sets of filter bundles. A similar arrangement is shown in Figure 5 utilising only three co-extensive filter bundles. At this stage, the use of either two or four co-extensive filter bundles
15 lengths is preferred.

Each filter bundle comprises a multitude of micro-porous polymeric hollow fibres of the kind wherein feed to be filtered is fed to the outside of the bundle of fibres and permeate is extracted from one or both permeate discharge ends 4 of the fibre lumens. These bundles are usually "potted" at the discharge ends to readily facilitate separation
20 of the permeate from the feed and simultaneously retain the fibres in assembled bundles.

The preferred potting material is urethane, which is a thermo setting polymer. A shallow pre-pot tray is provided in the final peripheral shape required, that has a plurality of long spaced apart spikes. The fibres are arranged in the tray and the resin is cast,

blocking off the fibre lumens at the end. The pre-pot trays are then removed and the bundle is placed into a centrifuge with second pot moulds, and additional urethane is introduced via the holes in the pre-pot moulding formed by the spikes. Once the second pot has cured, the pre-pot end section plus a section of the second pot is sliced off,
5 thereby clearly exposing the ends of the fibre lumens.

Also provided within the housing are one or more longitudinally extending feed passages. In the embodiment illustrated in Figures 1 and 2, the feed passages comprise a generally annular outer feed passage 6 (of preferably no more than about 15mm) that extends around the periphery of the groups of filter bundles 3 and a central feed passage
10 7 that extends through the central core of the housing. In the embodiments illustrated in Figures 3 to 5, the bundles have an outer casing including packing means that extends up to the periphery of the outer housing, the casing including means to direct the flow of feed both around and into the filter bundles. The central feed passage may similarly include formations in the form of baffles and the like for diverting the feed both into and
15 around the filter bundles as shown in Figure 3.

One or more longitudinally extending permeate return passages 8 are also provided which similarly extend parallel to the filter bundles, each of the permeate return passages being in fluid flow communication with each of the permeate discharge ends 4 of the fibre lumens via connecting passages 9 (see Figure 1). Means in the form of valves or
20 the like may also be provided (not shown) for selectively isolating an individual filter bundle, filter assembly housing, or manifold arrangement in the event of failure.

Disposed at one or both longitudinal ends of each housing 2 is a manifold or header arrangement shown generally at 10. Each header includes a feed inlet port 11 that

is in fluid flow communication with the longitudinally extending feed passages 6 and 7, and a permeate outlet port 12 which is in sealed and separate communication with the permeate return passages 8.

Referring in particular to Figures 6 and 7, it can be seen how the arrangement of the previous Figures can be built up in a modular construction by connection of suitably
5 configured headers to form large, yet highly compact, three dimensional arrays from a number of two dimensional banks.

In use, the system operates in substantially the same manner as the prior art filtration processes. Where there is provision for backwash facilities, the system outlet is
10 shut off and fluid is applied under pressure to the permeate to discharge outlet in a manner whereby it is passed through the membranes to dislodge contaminants that have accumulated on the outer feed surfaces. A flushing fluid, which is often feed, is then usually applied to the cross-flow feed outlet port for passage through the system so as to flush out any dislodged contaminant matter.

15 It can be seen that the system according to the invention provides a means of substantially increasing the packing density of the filter fibre bundles whilst simultaneously reducing the overall cost of the system by minimising the number of expensive header arrangements and connecting pipe work. For example, experimentation carried out by the applicant has indicated that the present invention can
20 result in a system that is 40% less expensive and 60% smaller than a plant employing the applicants current M10C technology.

Furthermore, tests have shown there is little or no compromise in the operating efficiency, as potential pressure drop problems are reduced by the provision of the feed

passages and the permeate connecting passages 9 which allow the permeate to discharge to the permeate return passages at each discharge end of the filter bundles. See for example Figures 8 and 9 which show that for the same flux (ie flow rate per unit area) the trans membrane pressure drop (TMP) for the system of the invention would be
5 comparable to that of the applicants significantly more costly current M10C technology. This provision of the intermediate permeate connecting passages also helps overcome pressure drop problems that would ordinarily be encountered during the backwash cycle.

It has also been observed that the present invention enables a significant reduction in backwash volume as compared to the applicants M10C technology particularly with
10 respect to the sweep stage, as in theory at least, the same volume of sweeping fluid is required to flush out dislodged contaminants for four bundles in series, as is required for only one bundle. It also appears that the system of the invention is potentially capable of higher flow rates for a given physical size than most of the relevant prior art systems.

Whilst the invention has been described with reference to specific examples, it will
15 be appreciated by those skilled in the art, that the invention may be embodied in many other forms.

CLAIMS:-

1. A filter assembly comprising:

an elongate housing having a plurality of discrete filter bundle lengths disposed end to end in a series configuration, each filter bundle comprising a multitude of microporous
5 polymeric hollow fibres, wherein feed to be filtered is fed to the outside of the bundle of fibres and permeate is extracted from one or both discharge ends of the fibre lumens;

one or more feed passages extending longitudinally along said housing to direct feed to said filter bundle lengths;

one or more longitudinally extending permeate return passages extending generally
10 parallel to said filter bundle lengths, said permeate return passages being sealed from contact with said feed and adapted to be in fluid flow communication with each of said permeate discharge ends of said fibre lumens in said filter bundle lengths; and

one or more manifold arrangements, each having a feed inlet port connecting with said one or more longitudinally extending feed passages and a separate permeate outlet port
15 connected with said one or more permeate return passages.

2. A filter assembly according to claim 1, wherein said manifold arrangements are disposed at one or both longitudinal ends of said housing and are adapted to connect a plurality of filter assemblies into banks.

3. A filter assembly according to claim 1 or claim 2, wherein said housing includes
20 between two and four filter bundle lengths disposed end to end in a series configuration.

4. A filter assembly according to any one of claims 1 to 3, wherein each longitudinal length of said housing has therein two or more co-extending filter bundle lengths that are each similarly connected in series to adjacent filter bundle lengths.

5. A filter assembly according to claim 4, wherein each longitudinal length of said housing contains three or four co-extensive filter bundle lengths connected in series, the system including at least one generally peripheral feed passage located in the housing generally parallel to the external walls thereof, and a central feed passage that passes
5 through the centre of the three or four co-extensive filter bundles.
6. A filter assembly according to claim 5, wherein said housing includes three or four separate permeate return tubes, equally spaced within said housing, intermediate said central and peripheral feed passages.
7. A filter assembly according to any one of the preceding claims, wherein said
10 manifold arrangements are in the form of headers located at both longitudinal ends of said housing thereby facilitating cross-flow filtration wherein a portion of the feed is discharged from the end remote the feed inlet for recirculation.
8. A filter assembly according to any one of claims 1 to 7, wherein said feed outlet port is adapted for use as a flushing fluid inlet port for operation during a backwashing process,
15 wherein fluid under pressure is applied to the inner surface of the fibre lumens via the permeate outlet ports and a backwashing fluid is subsequently applied to the external surfaces of the fibres via the flushing fluid inlet port, to flush out any accumulated contaminants that may have been dislodged from the fibres.
9. A filter assembly according to any one of the preceding claims utilising large
20 diameter filter bundles, wherein the system includes additional feed passages through the centre of each filter bundle length.
10. A filter assembly according to any one of the preceding claims including means to isolate individual filter bundles or banks of filter bundles in the event of failure of a filter bundle length.

11. A filter assembly according to claim 10, wherein said isolation means includes individual valves associated with each filter bundle, or filter assembly housing, or filter assembly manifold arrangement.
12. A filter assembly according to any one of the preceding claims wherein some form of
5 packing is provided intermediate the filter bundles and the housing which is configured to assist in directing the flow of feed both around and into the filter bundles.
13. A filter assembly according to any one of the preceding claims including transversely extending permeate connecting passages provided at each discharge end of the filter bundles to direct permeate from the fibre lumens to the permeate return passages.

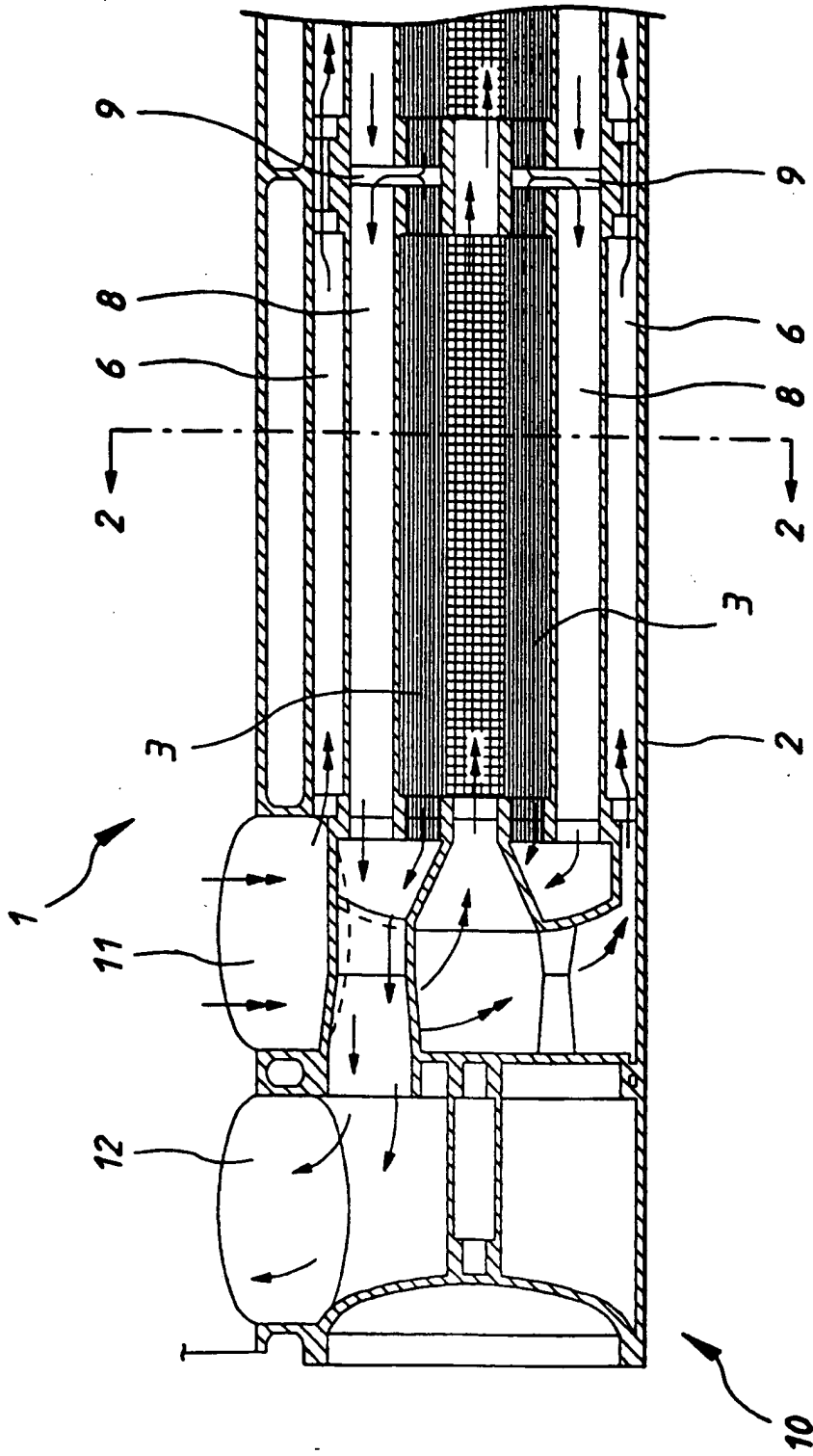

FIG.1

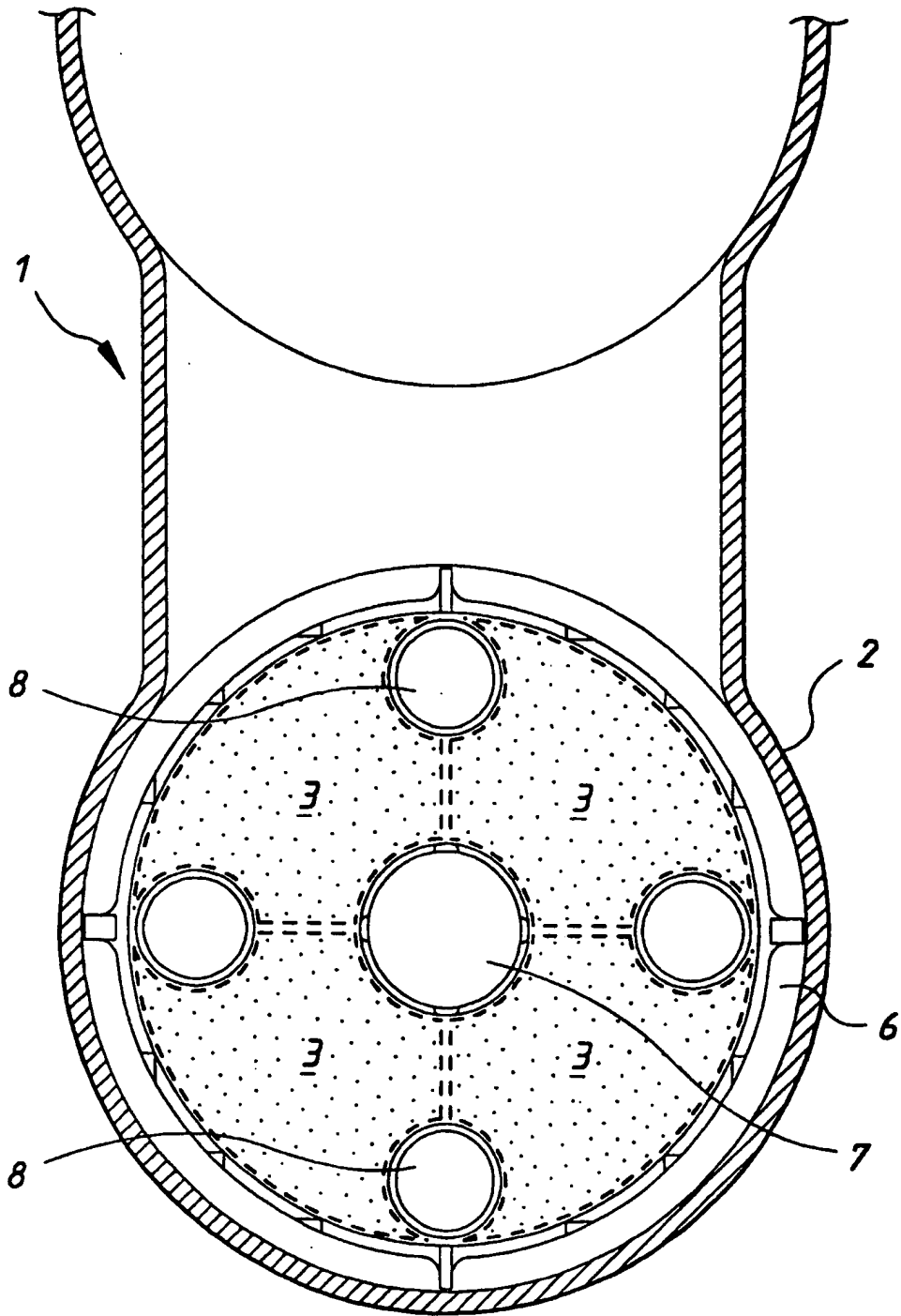

FIG.2

3/8

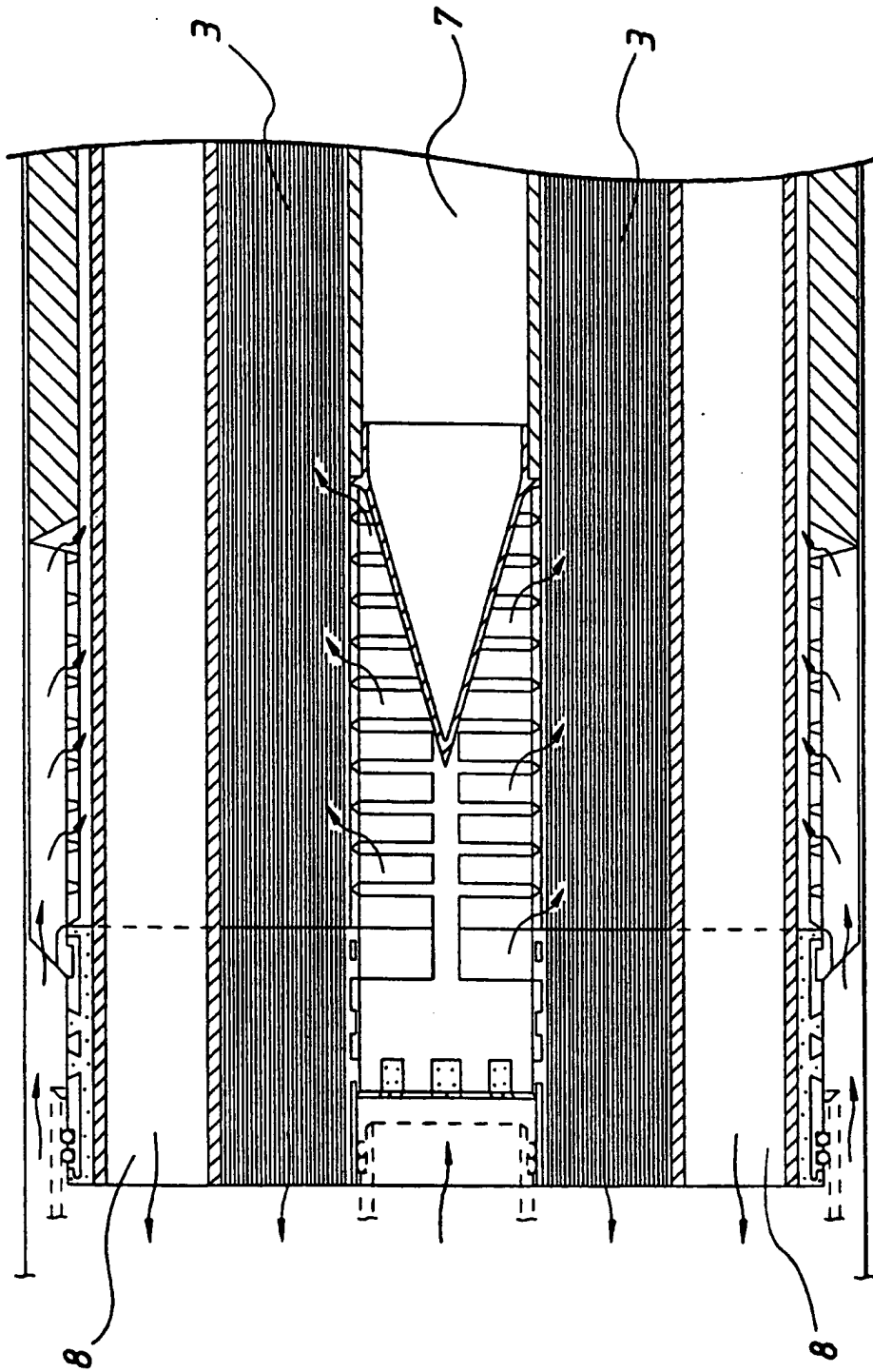

FIG.3

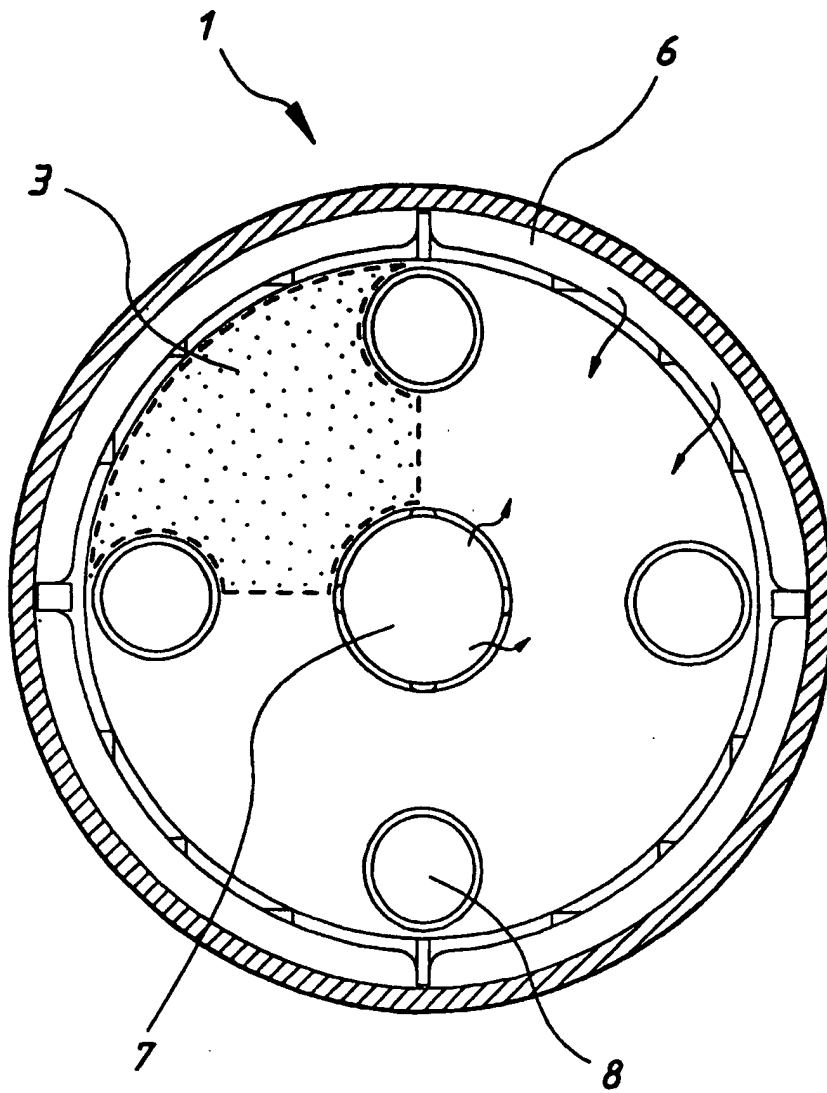

FIG.4

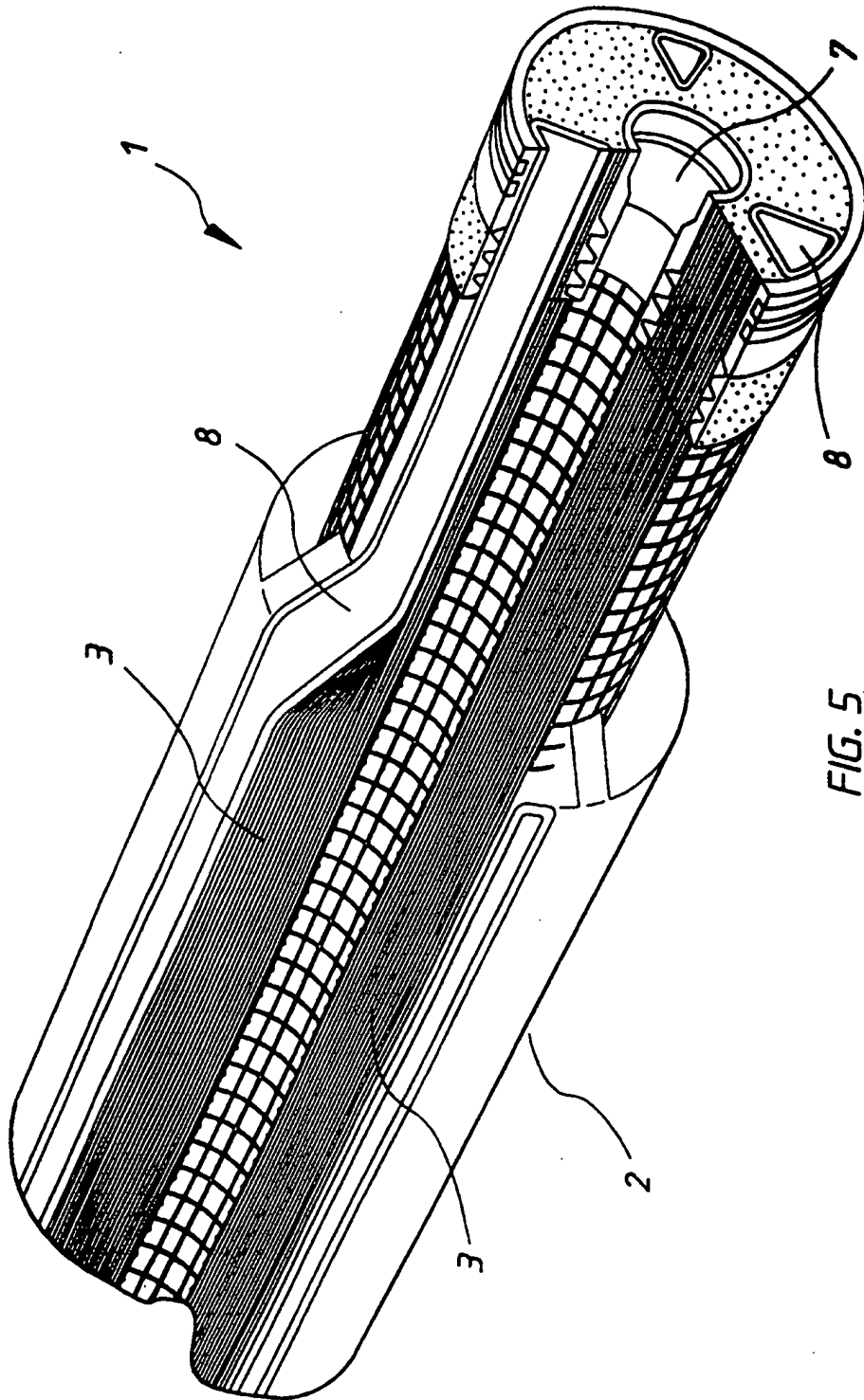

FIG. 5

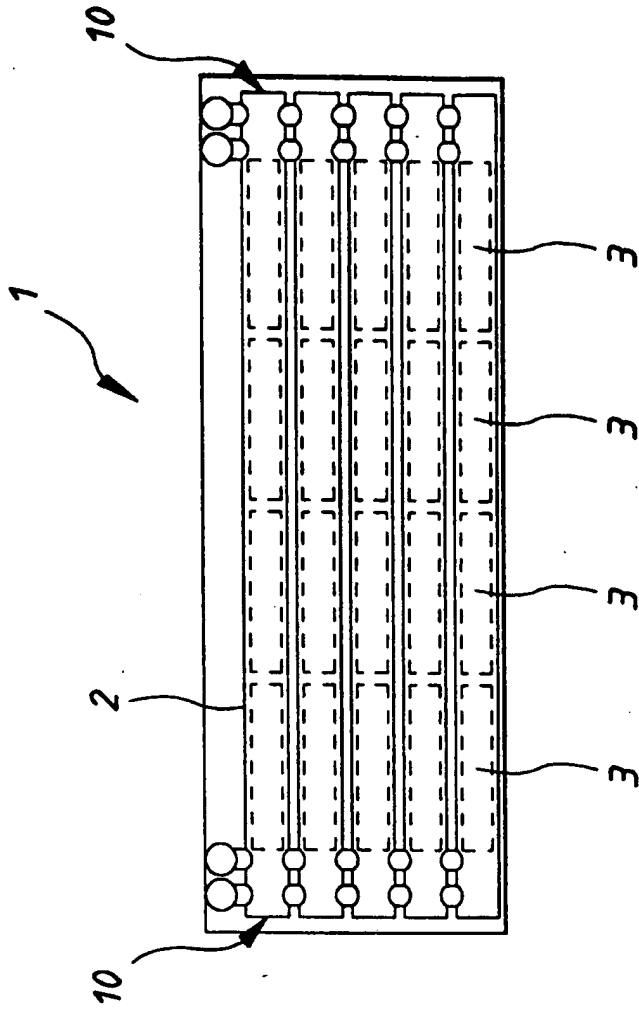

FIG. 7

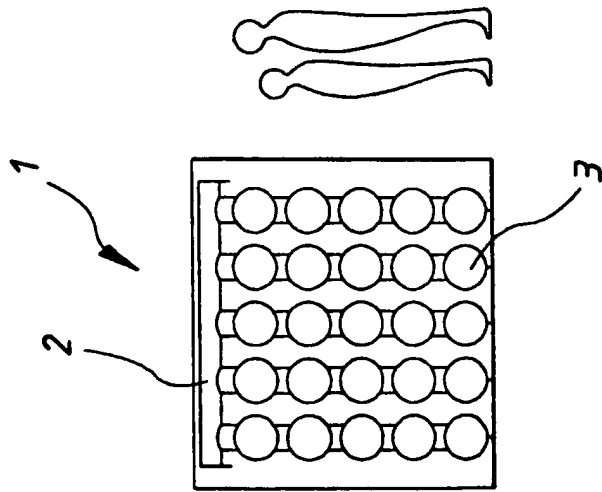

FIG. 6

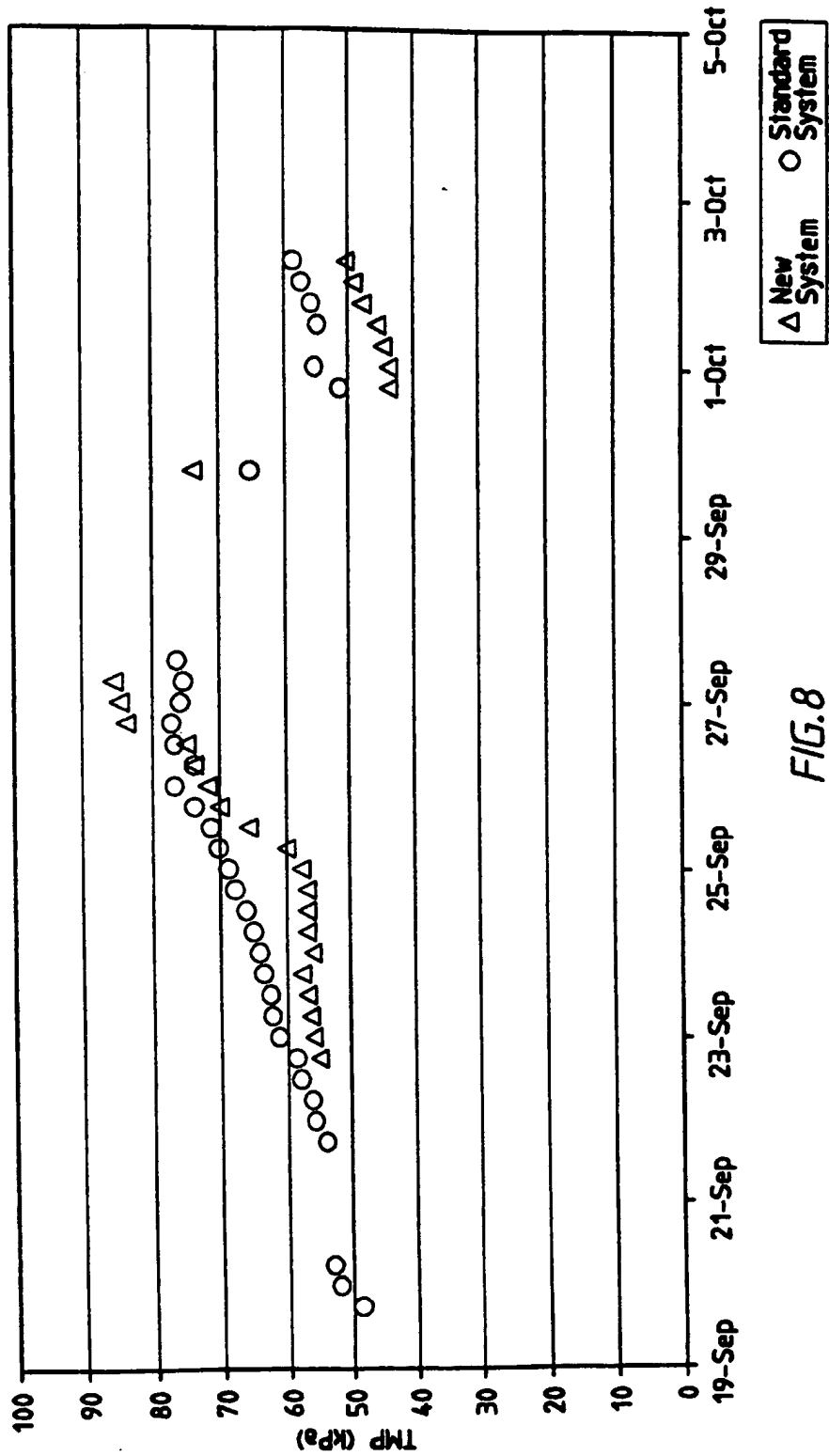

FIG. 8

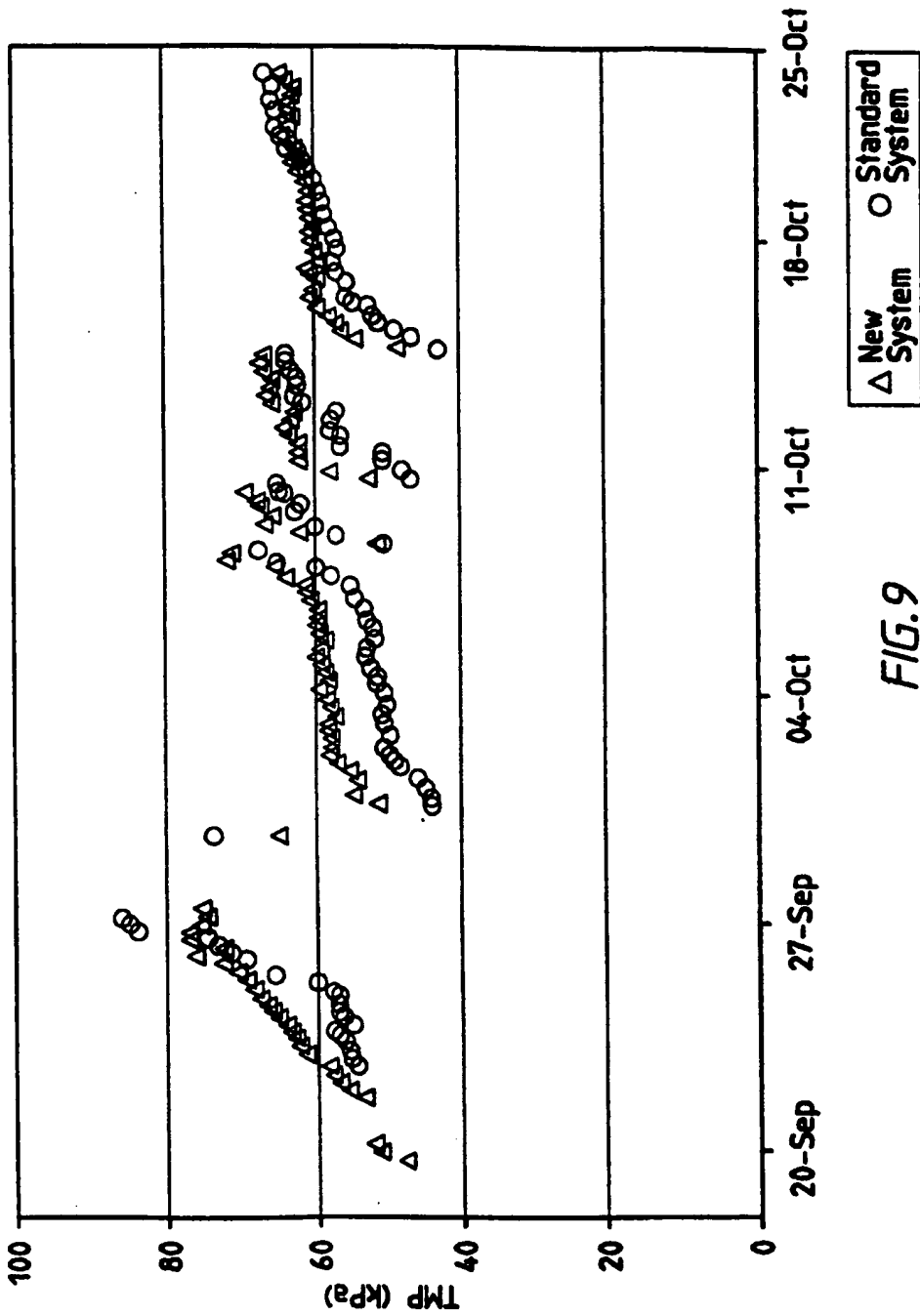

FIG. 9

INTERNATIONAL SEARCH REPORT

International Application No.
PCT/AU 97/00835

A. CLASSIFICATION OF SUBJECT MATTER		
Int Cl ⁶ : B01D 63/02 // B01D 63/04, 61/18		
According to International Patent Classification (IPC) or to both national classification and IPC		
B. FIELDS SEARCHED		
Minimum documentation searched (classification system followed by classification symbols) IPC : B01D 63/02, 63/04, 61/18, 13/00, 13/01		
Documentation searched other than minimum documentation to the extent that such documents are included in the fields searched		
Electronic data base consulted during the international search (name of data base and, where practicable, search terms used) WPAT, JAPIO : IPC B01D 63/02, 63/04, 61/18, 13/00, 13/01		
C. DOCUMENTS CONSIDERED TO BE RELEVANT		
Category*	Citation of document, with indication, where appropriate, of the relevant passages	Relevant to claim No.
X	US 4451369 (Sekino et al.) 29 May 1984 col 3 lines 21-58, col 4 line 20 to col 5 line 28, col 6 lines 27-32 and figs 1-3	1-5, 7-13
X	US 5470469 (Eckman) 28 November 1995 col 4 lines 60-66, col 10 line 61 to col 11 line 24, col 7 lines 14-16 and fig 3	1-5, 7-11, 13
A	US 5137631 (Eckman et al.) 11 August 1992 col 3 lines 15-27, lines 38-45, col 4 line 62 - col 5 line 2, col 5 line 55 - col 6 line 17 and fig 1	1, 3, 13
<input checked="" type="checkbox"/> Further documents are listed in the continuation of Box C <input checked="" type="checkbox"/> See patent family annex		
<p>* Special categories of cited documents:</p> <p>"A" document defining the general state of the art which is not considered to be of particular relevance</p> <p>"E" earlier document but published on or after the international filing date</p> <p>"L" document which may throw doubts on priority claim(s) or which is cited to establish the publication date of another citation or other special reason (as specified)</p> <p>"O" document referring to an oral disclosure, use, exhibition or other means</p> <p>"P" document published prior to the international filing date but later than the priority date claimed</p> <p>"T" later document published after the international filing date or priority date and not in conflict with the application but cited to understand the principle or theory underlying the invention</p> <p>"X" document of particular relevance; the claimed invention cannot be considered novel or cannot be considered to involve an inventive step when the document is taken alone</p> <p>"Y" document of particular relevance; the claimed invention cannot be considered to involve an inventive step when the document is combined with one or more other such documents, such combination being obvious to a person skilled in the art</p> <p>"&" document member of the same patent family</p>		
Date of the actual completion of the international search 5 February 1998		Date of mailing of the international search report 13 FEB 1998
Name and mailing address of the ISA/AU AUSTRALIAN INDUSTRIAL PROPERTY ORGANISATION PO BOX 200 WODEN ACT 2606 AUSTRALIA Facsimile No.: (02) 6285 3929		Authorized officer ROGER HOWE Telephone No.: (02) 6283 2159

INTERNATIONAL SEARCH REPORT

International Application No.
PCT/AU 97/00835

C (Continuation) DOCUMENTS CONSIDERED TO BE RELEVANT		
Category*	Citation of document, with indication, where appropriate, of the relevant passages	Relevant to claim No.
A	US 4670145 (Edwards) 2 June 1987 col 1 lines 49-53, col 2 line 42-53, figs 1 and 6	1, 3, 13

INTERNATIONAL SEARCH REPORT
Information on patent family members

International Application No.
PCT/AU 97/00835

This Annex lists the known "A" publication level patent family members relating to the patent documents cited in the above-mentioned international search report. The Australian Patent Office is in no way liable for these particulars which are merely given for the purpose of information.

Patent Document Cited in Search Report				Patent Family Member			
US	4451369	EP	55839	JP	57102202		
US	5470469	EP	781163	WO	96/08306		
US	5137631	EP	610323	IL	101848	WO	93/07958

END OF ANNEX